

PASLANMAZ ÇELİK TAM GEÇİŞLİ PN16 FLANŞLI İKİ PARÇALI ELEKTRİK AKTÜATÖRLÜ KÜRESEL VANA
STAINLESS STEEL 304/316 FULL PORT PN16 FLANGED 2- PC BALL VALVE WITH ELECTRIC ACTUATOR

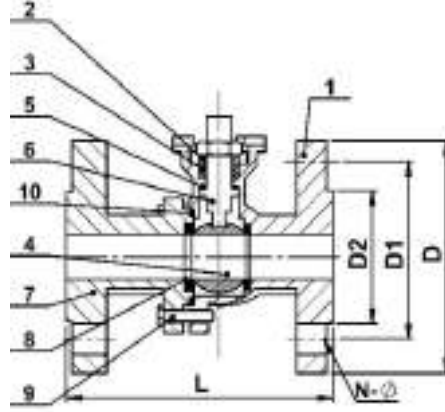

MODEL NST-EAK2PF

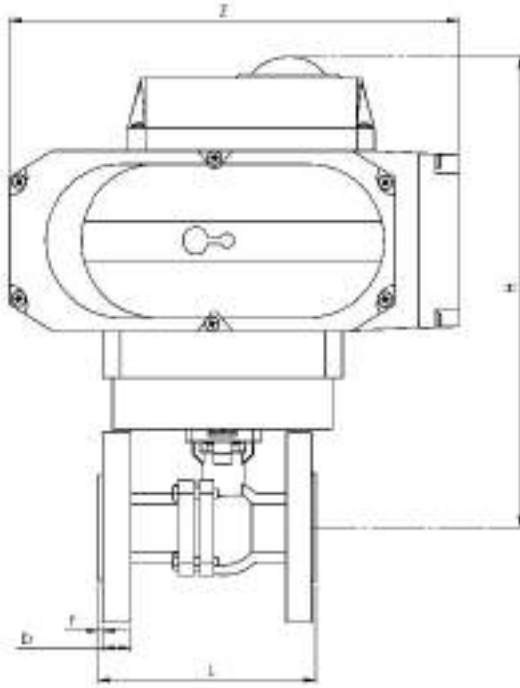

NO	PARÇA ADI / PART NAME	MALZEME / MATERIAL
1	GÖVDE / BODY	ASTM A351 GR.CF8
2	BASKI PULU / THRUST WASHER	PTFE
3	SALMASTRA / PACKING	PTFE
4	KÜRE / BALL	ASTM A351 GR.CF8M
5	MİL SALMASTRASI / SHAFT PACKING	PTFE
6	MİL / SHAFT	PASLANMAZ ÇELİK / SS304
7	KAPAK / CAP	ASTM A351 GR.CF8
8	SİT / SEAT	PTFE
9	CİVATA / BOLT	PASLANMAZ ÇELİK / SS304
10	CONTA / GASKET	PTFE

ÖLÇÜ SIZE	PN	L	D	D1	D2	H	Z	N-Ø	b	f	C°C	AKTÜATÖR ACTUATOR	TORK TORQUE Nm	AĞIRLIK WEIGHT KGS
DN15	16	115	95	65	45	208	160	4-14	14	2	9	NST-EA05	15.6	
DN20	16	120	105	75	54	208	160	4-14	15	2	11	NST-EA05	15.6	
DN25	16	125	115	85	65	216	160	4-14	16	2	11	NST-EA05	29.3	
DN32	16	130	135	100	78	221	160	4-18	16	2	14	NST-EA05	58.2	
DN40	16	140	145	110	85	253	196	4-18	17	2	14	NST-EA10	58.2	
DN50	16	150	160	125	100	260,5	196	4-18	18	2	14	NST-EA10	91.5	
DN65	16	170	180	145	120	326	256	4-18	18	2	17	NST-EA20	91.5	
DN80	16	180	195	160	135	338	256	4-18	18	2	17	NST-EA20	133	
DN100	16	190	215	180	155	339	256	8-18	20	2	17	NST-EA20	277	